

MP-4V Heavy Duty Riveter / 39048



This newly designed heavy-duty air/hydraulic riveter is ergonomically designed with the professional in mind. The light weight 3.7 lbs. well balanced MP-4V includes a *Vacuum system* and is designed to maximize a 1" stroke and 3,420 lbs. of pulling force with a 3 jaw setup that gets the job done. The air supply can be connected directly or you can use the supplied swivel air connector with the attached hose for operator convenience. Each tool is supplied with nosepieces to set 5/32"- 1/4" rivets in all alloys. A 1/4" monobolt nosepiece is included in addition to adjustment service wrenches, hydraulic fluid, fluid applicator, spare jaws and an air off/on valve. The adjustable *Vacuum System* control knob located on the side of the tool allows you to control the force of the air needed to hold the rivet in place or you may operate with the vacuum system turned off.

Recommended air pressure is 70-95 PSI.

**Alcoa
Fastening
Systems**



Alcoa Fastening Systems
1925 N MacArthur Dr
Suite 200
Tracy, CA 95376



WARNING:
ALWAYS WEAR SAFETY GLASSES
WHEN OPERATING AND PERFORMING MAINTENANCE ON

LA-534

AIR FEED

Use only compressed air. Check airline for damage from humidity & contaminants. In order to protect the tool from premature wear, we recommend the use of a filter, lubricator & regulator. Air connection size 1/4" NPT.

WARNING:
Do not use air supply greater than recommended or tool may be damaged or burst.



1. Connect air supply then switch ON/OFF valve to ON position

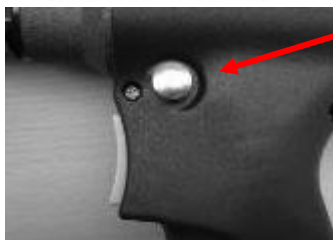

2. To turn on and adjust vacuum system rotate silver knob on side of tool and turn it clockwise until desired amount of vacuum is obtained to hold rivet in place and eject spent mandrel into the collection cup. If you don't want to use the vacuum system rotate the silver knob counter-clockwise to shut it off. The tool will still function but must be tilted backwards to allow spent mandrel to fall into collection cup.



Fig 3

ADDITION OF HYDRAULIC FLUID

1. Disconnect air supply to tool and switch ON/OFF valve to OFF position.

2. Remove seal screw and seal (see Fig. 3)

3. Screw the priming pump of filled oil into the bleed screw hole. Actuate the priming pump by pressing down and releasing several times until resistance is felt. (Fig. 4)

4. Remove the priming pump and the excessive oil will flow out. Wipe away and clean out the excessive oil and replace the seal and screw.



Fig 4

IMPORTANT: Use only Anti-Foam Hydraulic Fluid

WARNING:
ALWAYS WEAR SAFETY GLASSES
WHEN OPERATING AND PERFORMING MAINTENANCE ON TOOL

CHANGING NOSEPIECES

1. After selecting the correct size nosepiece for the rivet being used Connect tool to air supply and pull trigger and hold trigger button.
2. Using wrench (supplied), unscrew nosepiece from frame head & replace with proper size nosepiece. Tighten down with wrench. DO NOT OVERTIGHTEN. Release trigger.

Your tool is now ready to work. Insert rivet mandrel into nosepiece. Insert rivet into predrilled hole in application and pull trigger button and hold until rivet sets then release the trigger. A second pull may be required.

CLEANING & CHANGING OF JAWS

With use, the jaws of the tool may become dirty or worn. This will cause slipping of the rivet mandrel & and improper setting of the rivet. To clean the jaws follow this procedure.

1. Disconnect air supply.
2. Use a suitable wrench, unscrew frame head and remove.
3. Using a pair of wrenches, disassemble front jaw case from rear jaw case. DO NOT MOVE rear jaw case as this will affect tool operation.
4. To clean jaws, use a stiff dry wire brush.
5. If excessive wear is apparent, replace with new jaws.
6. Reassemble the jaw case assembly.

MP-4V (39048) Breakdown

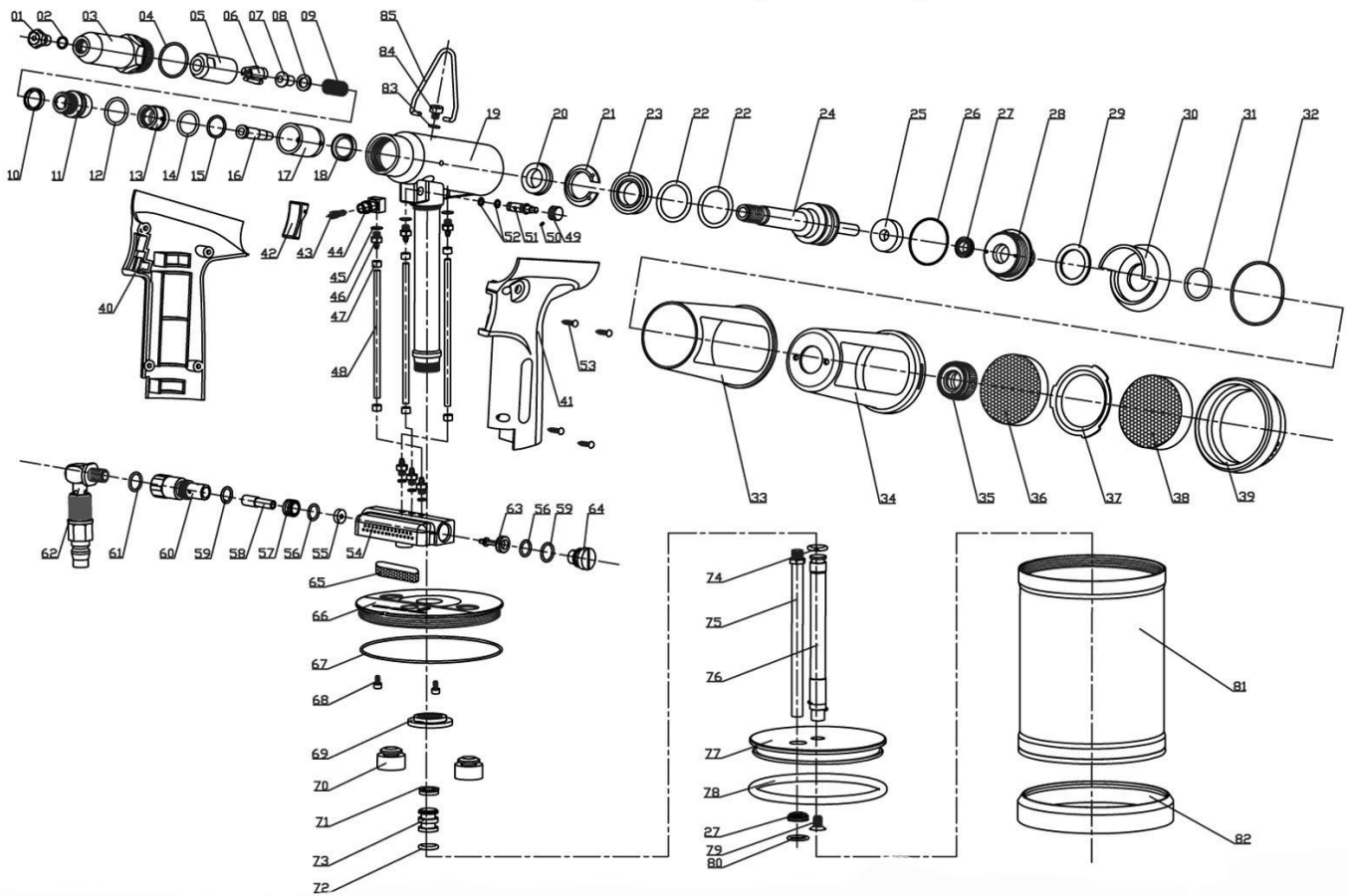

Part Number	AFS Part No.	Description
1	M95300	5/32" Nosepiece
1	M95301	3/16" Nosepiece
1	M95302	1/4" Nosepiece (Standard)
1	M95303	1/4" Nosepiece(Monobolt)
2	M95304	O-Ring (meas.9x1)
3	M95305	Nosepiece casing
4	M95306	O-Ring (meas.22x2)
5	M95307	Jaw housing
6	M95308	Jaws (3pcs)
7	M95309	Pusher
8	M95310	Washer
9	M95311	Jaw pusher spring
10	M95312	Lock ring
11	M95313	Housing
12	M95314	Polyurethane ring (meas. 16x2)
13	M95315	Set nut
14	M95316	Polyurethane ring (meas. 14.3x2)

Part Number	AFS Part No.	Description
15	M95317	O-Ring (meas. 13x16x1.5)
16	M95318	Vacuum sleeve
17	M95319	Seal plastic housing
18	M95320	Sealing ring (meas.2 5x13.5x3.5)
19	M95321	Head assembly
20	M95322	Lip Seal (meas.14x11x6.3)
21	M95323	O-Ring 48
22	M95324	O-Ring (meas. 26.7x3 26x1.78)
23	M95325	Lip Seal (22x30x6)
24	M95326	Axis
25	M95327	Buffer
26	M95328	O-Ring (meas.35x1.5)
27	M95329	EL(meas. 8x14x5)
28	M95330	End cap
29	M95331	Plastic ring (3 3x21x1.8)
30	M95332	Stem collector adaptor
31	M95333	O-Ring (meas.24x2)
32	M95334	O-Ring (meas.47x1.5)
33	M95335	Stem collector outer
34	M95336	Stem Collector body
35	M95337	Retaining nut
36	M95338	Silencer
37	M95339	Stem collector end cap
38	M95340	Silence
39	M95341	Silencer cap
40	M95342	Handle (left)
41	M95343	Handle (right)
42	M95344	Trigger
43	M95345	Trigger valve
44	M95346	On/Off base
45	M95347	O-Ring (meas.6x1)
46	M95348	Air interface
47	M95349	Tie ring
48	M95350	Air tube
49	M95351	Regulatable button
50	M95352	Retaining screw (meas.3x3)
51	M95353	Vacuum valve
52	M95354	O-Ring (meas. 4x6x1)
53	M95355	Tapping screw (meas.3x10)

IF further maintenance is beyond the scope of this direction sheet and the tool fails to function properly, contact the factory or return it to the factory for service. Contact our Tool Repair Center at 317-704-8874 for further information.

LIMITED TOOL WARRANTY

Alcoa Fastening Systems - Marson division warrants that this tool will be free from defects in material and workmanship under normal service and for ninety (90) days from the date of purchase. This warranty applies to the purchaser of the tool for original use only. All other warranties, whether expressed or implied, including any warranties of merchantability or fitness for purpose are hereby excluded.

Should this tool fail during this ninety (90) day period, and no unauthorized repairs have been made, return the tool freight prepaid to the factory for free of charge replacement of any part or parts found by Alcoa Fastening System - Marson division to be defective due to faulty material or workmanship. This represents the sole obligation of Alcoa Fastening Systems - Marson under this warranty. In no event shall Alcoa Fastening Systems - Marson division be liable for any consequential or special damages arising from the purchase or use of this tool. You may have other rights which vary from state to state.