

HUCK® INTERACTIVE CD ROM : SPECIFICATIONS

2580

2580

Hydraulic Installation Tool

Specifications

Weight:

2.98 (6.58 lbs.)

Stroke:

24 mm (0.94")

Operating Hydraulic Pressures:

Pull- *max 393 bar (*5700 psi)

Return-221 bar (3,200 psi)

* For fastener diameter 9.5 mm (3/8")

and above use 510 bar (7400 psi)

Capacity:

36,65 kN @ 393 bar

(8240 lbs @ 5700 psi)

47,6 kN @ 510 bar

(10700 lbs @ 7400 psi)

Part of the FOCUS Tooling Range

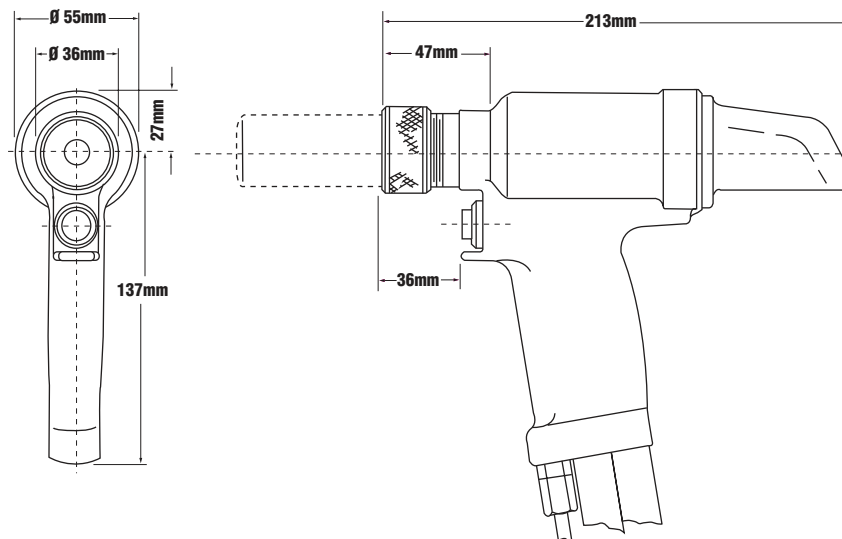

HUCK® INTERACTIVE CD ROM : NOSE ASSEMBLY TABLE

2580

Some Fasteners & Nose Assemblies for use with the 2580 Tool

Type	Diameter	Nose Assembly
BOM	4.8 mm ($\frac{3}{16}$ "	99-1053
	6.4 mm ($\frac{1}{4}$ "	99-830-1
	7.9 mm ($\frac{5}{16}$ "	99-769
	9.5 mm ($\frac{3}{8}$ "	99-1272
MAGNA-LOK	9.5 mm ($\frac{3}{8}$ "	99-3318
MAGNA-BULB	7.9 mm ($\frac{5}{16}$ "	99-3307
C6L/C120L	4.8 mm ($\frac{3}{16}$ "	99-2558
	6.4 mm ($\frac{1}{4}$ "	99-2564
	7.9 mm ($\frac{5}{16}$ "	99-99-245
	9.5 mm ($\frac{3}{8}$ "	99-100-245
MAGNA-GRIP	4.8 mm ($\frac{3}{16}$ "	99-3206
	6.4 mm ($\frac{1}{4}$ "	99-3207
	7.9 mm ($\frac{5}{16}$ "	99-1439
	9.5 mm ($\frac{3}{8}$ "	99-1440
HUCKTAINER	9.5 mm ($\frac{3}{8}$ "	99-3438

Items in **bold** are part of our FOCUS Tooling Range